

**STEP 1
 INSTALL**

- Confirm contents of package: 1 sensor, 1 cable, 1 wide lens (default), 1 narrow lens, mounting template, User's Guide.
- Install the sensor at the desired location. Use the enclosed mounting template for drilling locations.

**STEP 2
 WIRING**

- Wire the sensor per the application. Generally, the output wires (brown and blue) will connect to safety at the door control. The relay output from the IRIS is a dry contact. Note: The IRIS cable is the same as a Wizard II cable. Wire color and connection points are identified below.

Red	Power: 12 to 24 VAC / DC (+)
Black	Power: 12 to 24 VAC / DC (-)
White	Relay 1: Auxiliary Output
Green	Relay 1: Auxiliary Output
Brown	Relay 2: COM (to COM input at door control)
Blue	Relay 2: NO (to SAFETY input at door control).

**STEP 3
 POWER-ON**

- Apply the specified power and observe the red LED on the IRIS.
- Red LED should come on, and remain on throughout the setup. Door should remain open during setup. When complete, red LED goes out, and door should close. This takes about 6 seconds if uninterrupted.
- IMPORTANT NOTE: During sensor setup, the sensor may or may not cause a door opening cycle. This is because the output from the sensor may be tied to the safety circuit of the door controller, which is typically disabled at the closed door position. For a quick setup, this is Ok. For an assisted setup, the installer must launch the setup, then active the door to the open position immediately thereafter. A normal setup routine will then follow.

**STEP 4
 SETUP**

- The most common defaults have been applied to the sensor. Below, are the most critical for proper door operation, and are the first ones to check if unexpected behavior occurs:
 - ✓ Relay Configuration: By default it is set to Active (value 4) – the IRIS relay contact closes upon detection. If passive is required, change the output configuration value to 1. The most obvious indication to this condition is that the door works in reverse order – no detection results in hold open.
 - ✓ Pulse Frequency: If an interference is suspected from other nearby sensors or IR equipment, change the frequency of the IRIS. Default is value 1, change to value 3. Values 2 and 4 are not used.

**STEP 5
 IR ANGLE**

- Additionally, the angle of the infrared curtain will need to be adjusted. If the curtain is too close to the door, the door will appear to recycle on its own. A curtain that is too far from the door will be in violation of applicable standards – for most applications.
- Adjust the curtain so that detection occurs within 3" from the face of the door. Turn the adjustment screw in clockwise to draw the curtain in closer to the door.

**STEP 6
 WALK-TEST**

- Always walk-test the sensor pattern when completed. The performance of the sensor should comply with all standards relative to the application.
- As a minimum, the sensor pattern width should be equal to or greater than the width of the clear door opening.
- To test the performance of the sensor, stand motionless in the detection area for 30 seconds. Door should stay open with no attempt to close.

**STEP 7
 DOCUMENTATION**

- Document all work. For future reference, be sure to record the IRIS serial number on your work order.
- Educate the Owner / Manager as to the proper operation of the sensor, and door system, and what to do to ensure safe use of the door in the event of discovering a malfunction. Show them how to perform a daily safety check of the sensor.

NOTE: Be sure to reference the complete User's Guide if additional information is required.

1 Description

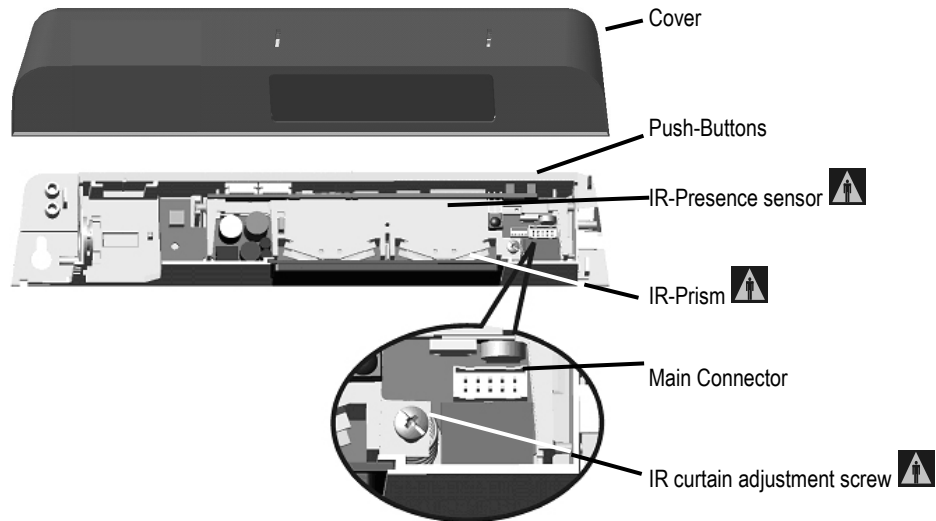

2 Technical Specifications

Supply voltage	: 12V (-5%) to 24V (+10%) AC/DC
Mains frequency	: 50 - 60 Hz
Power consumption	: < 3 W
Mounting height	: 6'8" TO 13'
2-color LED	: RED (presence detection) – ORANGE (signal saturation, error)
Temperature range	: -22°F to +131°F
Degree of protection	: IP54
Norm conformity	: EMC 89/336/EEC
Dimensions	: 10.3" (L) x 2.2"(H) x 1.43" (D)
Weight	: 8 oz.
Housing material	: ABS + LURAN S
Minimum length of cable	: 10' (3 m) - 9 conductor (10IRIS) : 30' (9 m) - 9 conductor (10IRIS-I)
Range of Remote Control	: 16'

 PRESENCE SENSOR										
Detection mode	Presence Response time: < 128ms									
Technology	Focused active infrared and self-monitored microprocessor Spot diameter (standard): 4" max Number of spots: 24 or 12 spots by curtain Number of curtains: 2									
Detection field (@ 7' Ht.)	<table border="1"> <thead> <tr> <th></th> <th>Width</th> <th>Depth</th> </tr> </thead> <tbody> <tr> <td>Wide</td> <td>6'6"</td> <td>13.75"</td> </tr> <tr> <td>Narrow</td> <td>3'3"</td> <td>13.75"</td> </tr> </tbody> </table>		Width	Depth	Wide	6'6"	13.75"	Narrow	3'3"	13.75"
	Width	Depth								
Wide	6'6"	13.75"								
Narrow	3'3"	13.75"								
Angle	From - 4° to + 4° (adjustable)									
Output specification	Relay: Max. contact voltage: 42V AC/ DC Max. contact current: 1A (resistive) Max. switching power: 30W (DC) / 60VA (AC)									
Output holdtime	1s (fixed)									

3 Installation

1 Tips



Use the Remote-Control to adjust the sensor.



Use the Spotfinder to locate the safety curtains.



Avoid touching optical parts!



Make sure the operator cover is fixed properly and electrically grounded.



Avoid vibrations!!!



Do not cover the sensor!

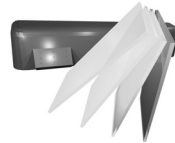

Avoid moving objects in proximity to the sensor!



Avoid highly reflective objects in the infrared field!

- DO NOT attempt any internal repair of the sensor. All repairs and/or component replacements must be performed by BEA, Inc. Unauthorized disassembly or repair....
 - ✓ may jeopardize personal safety and may expose one to the risk of electrical shock
 - ✓ may adversely affect the safe and reliable performance of the product
 - ✓ will result in a voided product warranty

2 Mounting the sensor: follow the instructions on the enclosed template



Mount the sensor at a maximum height of 2" from the bottom line of the door operator.

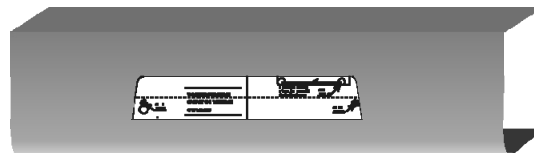

Use the mounting template to drill holes and position the sensor.

3 Wiring the sensor: wire according to the color designations (as shown below)

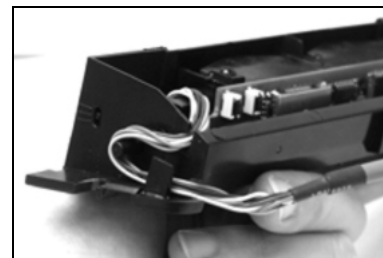
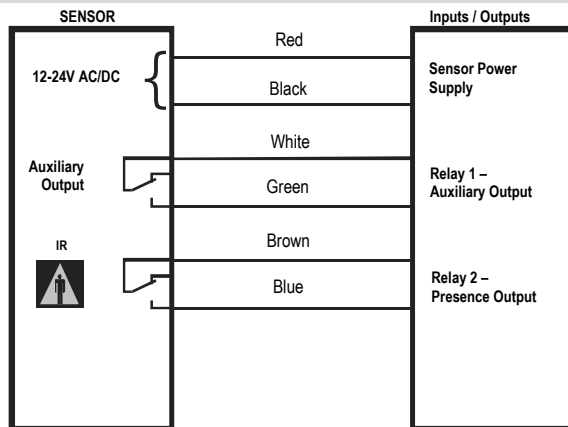

To ensure good water protection, route the cable as shown above.

4



IR presence sensing field: select the applicable IR lens – narrow or wide (default)

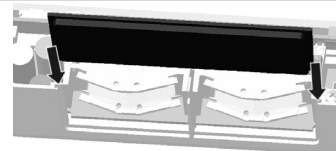
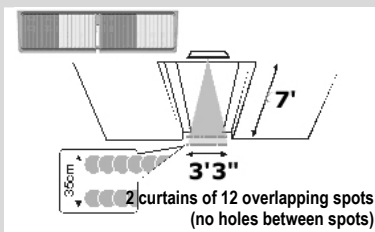
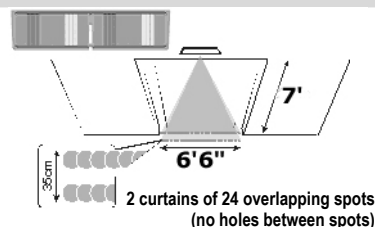

Install the applicable lens into the slots at bottom side of sensor. The default lens is wide.



Above 10' mounting height, use the narrow prism!

5



IR presence sensing field : Adjust the infrared curtain as shown below.

For automatic sliding doors the curtain should reach within 3" of the face of the sliding door panel.

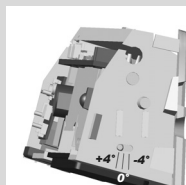
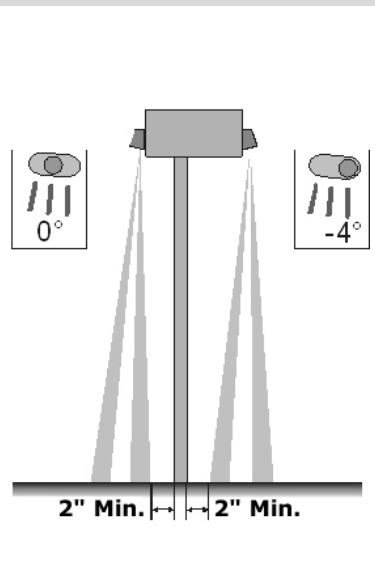

The pin shown here above indicates the angle adjusted.

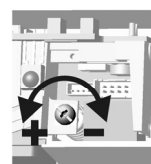

To approach the curtain to the door, turn the screw clockwise. To tilt the curtain out, turn the screw counterclockwise.



Use the Spotfinder (accessory) to locate and adjust the position of the curtains.



When mounting one sensor on each side of the door above a highly reflective threshold, select different frequencies to avoid crosstalk between the sensors.

4 Remote Control Set-up

1



Important User Guide Symbols



LED turns on



LED flashing slowly



LED flashing quickly



Presence detection

LED display during normal function



RED LED

Presence detection



ORANGE LED

See chapter 7: Troubleshooting

2



Remote Control adjustments (only when factory settings do not match)

Unlock the sensor to enter into adjustment session (if no access code has been entered)	Press Unlock key RED LED flashes slowly
To change the value of a parameter (ex. Maximum duration of presence detection)	Select parameter to change RED LED flashes quickly Enter new value RED LED flashes slowly
... to change any other parameters (ex. Output Configuration)	Select parameter to change RED LED flashes quickly Enter new value RED LED flashes slowly
To check the value of a parameter (ex. maximum duration of presence detection)	Select parameter to check RED LED flashes quickly Press Question Mark GREEN GREEN GREEN GREEN ... RED LED flashes slowly The number of green flashes indicate the value of this parameter
Lock the adjustment session and go back to normal function	Press Lock key twice

NOTE: LOCK ACCESS CODE:

When unlocking the sensor, if LED flashes quickly, enter the lock code OR if lock code is unknown, perform the following:

- Disconnect power from the sensor.
- Re-connect power.
- Press unlock within 60 seconds to bypass the lock code.
- When programming is complete, and the sensor is re-locked, the lock code will once again be required unless it is deleted as described below.

To re-lock the sensor without a lock code (or with a new lock code), perform the following:

- To return to no lock code, simply press lock once, followed by 0000.

3



Remote Control Programming: Launch a setup by performing the following:

Unlock the sensor to enter into adjustment session	Press Unlock key RED LED flashes slowly
To launch an assisted setup → required after mechanical adjustments of the IR sensor module. → required once after the first installation	Press Setup key followed by 0 RED/GREEN LED alternating The sensor performs a door opening and closing cycle to check the influence of the door leaves to the safety curtains. See Troubleshooting if RED LED flashes quickly after setup. This setup is only effective if the relay output (activation) has been wired to the door controllers opening impulse input. This is required to create a door opening/closing cycle.

LED display during sensor assisted setup

RED/GREEN LED	LED alternating means setup-process active: the sensor learns its environment. After finishing the setup process, the sensor shows the following behavior:
RED LED flashing quickly	The sensor 'sees' the door movement and can not finish its setup.
ORANGE LED continuously on	The sensor encounters a signal saturation (ex. due to a highly reflective floor).
No LED turns on	The sensor successfully finished its setup.

3



Remote Control Programming: Continued.

Door control F2

- 1 ♦ **normal**
(LED in normal mode)
- 2 door permanently open
(red LED ON)
- 3 door permanently closed
(red LED OFF / No monitoring reply)

Unlock

Check values

Lock

Output configuration

	Relay 1	Relay 2 (presence)
1	Active	Passive
2	Passive	Active
3	Passive	Passive
4 ♦	Active	Active

IR curtain immunity

- 1 normal
- 2 ♦ rain
- 3 snow

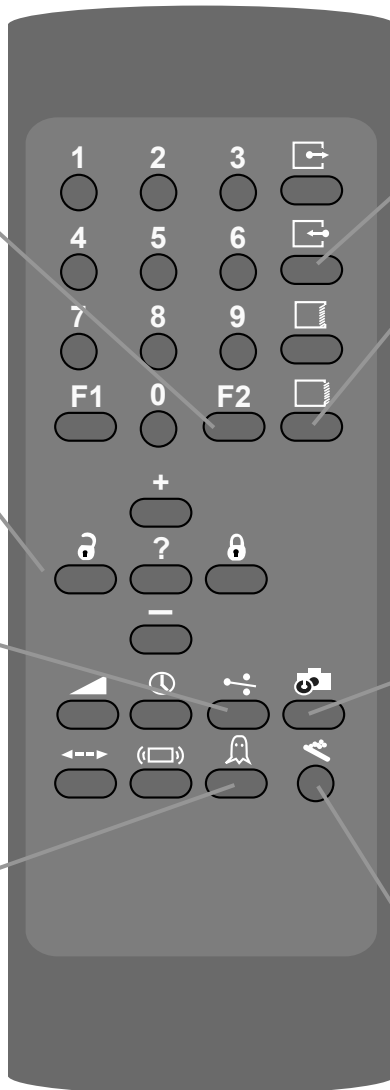

Number of IR curtains

- 1 1 curtain
(safety curtain close to the door)
- 2 ♦ 2 curtains
- 3 2 curtains (same as 2)

Installation Configuration

	Mounting Height	Pulse Frequency
SINGLE UNIT		
1 ♦	Low	Low
2	High	Low
3	Low	High
4	High	High
OVERLAPPING UNITS		
5	Low	Low
6	High	Low
7	Low	High
8	High	High

Max. duration of presence detection

0 ♦ 30 seconds for IRIS

- 1 = 1 minute
- 2 = 2 minutes
- 3 = 5 minutes
- 4 = 10 minutes
- 5 = 20 minutes
- 6 = 60 minutes
- 9 ♦ Infinity (no learn) for IRIS-I

Setup

- launch a setup
- 0 launch an assisted setup
- 9 restore factory settings

Important Note: Upon detection at the sensor, both relays will be simultaneous triggered. Relay 1 is assigned to the white and green output wires. Relay 2 is assigned to the brown and blue output wires. Both are dry contacts. BEA wiring diagrams show Relay 2 (brown and blue) as the designated output for presence detection. For the IRIS sensor, Relay 1 may be used as an auxiliary relay for triggering of other devices. Be certain to note the relay 'output specifications' on page 2. An Active relay is one that closes the contacts upon detection, a Passive relay will open the contacts upon detection.

4



Important Programming Notes

Door Control Mode	The Door Control Mode is used to simulate a permanent detection, or non-detection, and is a useful setting while performing service to the door.
Installation Configuration	The Installation Configuration key is used for changing the pulse frequency of the sensor for the purpose of reducing chances of cross-talk between sensors. To prevent crosstalk when installing overlapping units set one unit to 5 and the other to 7 for Low Mount or one unit to 6 and the other to 8 for High Mount.
Sensor Output	When launching a sensor setup, the sensor may or may not cause a door opening cycle. This is because the output from the sensor may be tied to the safety circuit of the door controller, which is typically disabled at the closed door position. For a quick setup, this is OK. For an assisted setup, the installer must launch the setup, then active the door to the open position immediately thereafter. A normal setup routine will then follow.
Lock Key	Always be sure to press the LOCK key twice, following any programming of the sensor. If the LOCK key is not pressed twice, the changes will not be permanently stored in the memory.
Rain Mode	Rain Mode: When the infrared immunity level is set to Rain Mode, a specific trigger is required to enter into the mode: If the sensor completes 2 learn cycles within 6 detections, it will enter into Rain Mode. During this mode, the sensor will change the 2 nd infrared curtain (the one farthest from the door) to IR motion (as opposed to IR presence). This will last for 1 hour, or until power is reset, or until a new setup is launched, whichever occurs first.
Snow Mode	Snow Mode: When the infrared immunity level is set to Snow Mode, a specific trigger is required to enter into the mode: If the sensor completes 2 learn cycles within 6 detections, it will enter into Snow Mode. During this mode, the sensor will change the 2 nd infrared curtain (the one farthest from the door) to IR motion (as opposed to IR presence). Additionally, the automatic learn time will change from whatever it was set to, to 10 seconds. This will last for 1 hour, or until power is reset, or until a new setup is launched, whichever occurs first. If Snow Mode is selected, additional beams or sensors may be required to maintain compliance with applicable safety standards.

5



Manual Setup Of The Sensor

Manual Setup Procedures

1. Set-up of the IRIS may be accomplished by the use of two IRIS mounted programming buttons. The procedures below indicate how to program using these buttons.
2. The two setup buttons are located at the right side of the IRIS (as viewed when mounted to header). To begin, briefly press the right button and move away from the sensing patterns.

TO RESET THE UNIT TO FACTORY DEFAULTS:

- Press and hold both buttons simultaneously until both red and green LED lights flash alternately

TO CUSTOMIZE SETTINGS FROM FACTORY DEFAULTS

- To enter the customizing mode: Press the right button until the LED light flashes and then release
- To return to standard mode: Press the right button again until the LED light stops flashing and then release

CUSTOMIZING MODE

- The red LED light indicates the number for the function being altered (1 flash = function #1)
- The green LED light indicates the value for the function being altered (1 flash means value = 1)
- The right button enables selection of the function number being altered (+1 for each press)
- The left button enables alteration (change in value) of the function (+1 for each press)
- See the chart below for the function assignments:
- An Orange LED will be displayed for those functions not utilized.









3. Use the chart below as an aide for the manual programming procedure.

5 Manual Setup Of The Sensor – continued

PARAMETER NUMBER (altered by the right button and confirmed by RED LED)	PARAMETER	VALUES (altered by the left button and confirmed by GREEN LED)	DEFAULT VALUE
1	Not Used	-	-
2	Relay hold time	-	-
3	Output configuration	1-4	4
4	Auto-learn presence sensing	0-9	0 = IRIS 9 = IRIS-I
5	Not Used	-	-
6	Not Used	-	-
7	IR Immunity	1-3	2
8	Not Used	-	-
9	Not Used	-	-
10	IR curtain	1-2	2
11	Not Used	-	-
12	Height & Frequency	1, 3	1
13	Not Used	-	-
14	Door control function	1-3	1
15	Not Used	-	-

REQUIRED: If the IR frequency has been manually changed, to prevent the sensors from being in permanent detection, momentarily depress the right program button to launch an assisted setup.

5 Helpful Hints

High mounting height (>10')	If the sensor is installed higher than 10' above the floor, make sure to use the narrow prism (See Ch. 3).				
Rain/Snow	If the sensor is exposed to rain or snow, use the URC (Universal Rain protection Cover) Set the sensor to immunity level 2 or 3 to increase the immunity of the sensor.				
Setup	<table border="0"> <tr> <td> 0 Assisted Setup (~14sec)</td> <td>Sensor checks the influence of the door leaves to the IR curtains (performs a door open/door close cycle)</td> </tr> <tr> <td>  Standard Setup (~4sec)</td> <td>Sensor only learns its environment</td> </tr> </table> <p>After adjusting the sensor for the first time, it is required to launch an 'Assisted Setup' (See Ch. 4). If the IR sensor module 'sees' the door movement, move the curtains out of the door leaf.</p>	 0 Assisted Setup (~14sec)	Sensor checks the influence of the door leaves to the IR curtains (performs a door open/door close cycle)	  Standard Setup (~4sec)	Sensor only learns its environment
 0 Assisted Setup (~14sec)	Sensor checks the influence of the door leaves to the IR curtains (performs a door open/door close cycle)				
  Standard Setup (~4sec)	Sensor only learns its environment				
Access Code	The access code is recommended to set sensors close to each other with remote control. The access code can be composed of 1 to 4 digits (factory values or no access code : 0 or 0000). No code is required to unlock during the first minute after powering. To enter a lock code, simply press the Lock key, followed by a lock code. If lock code is less than 4 digits, the lock key must be pressed a second time following the last digit of the code (See Pg. 5).				
Overlapping IR-curtains	Overlapping IR-curtains from sensors installed side-by-side may cause disturbances due to crosstalk (interferences). Select different frequencies on each sensor to avoid crosstalk (See Setting 'Installation Configuration' on Pg.6). Attention: avoid curtains that are overlapping by more than 12" (at 7' mounting height, using the wide prism).				

6 Accessories (sold individually)



PN: 10REMOTE

Remote Control: Used for easy programming of the sensor.



PN: 10SPOT

Spotfinder: Used to locate infrared sources. It is helpful in determining location of the infrared curtains emitted by the IRIS.



PN: 10WCA

WCA: This is a ceiling adaptor for use on drop ceilings (or otherwise). Maximum ceiling thickness allowed is about $\frac{3}{4}$ ".



PN: 10WMB

WMB: This is a 90-degree mounting bracket to allow installation on a flat horizontal surface.



PN: 10URC

URC: This is a universal rain cover to shield the sensor from direct rain contact.

7 Troubleshooting

SYMPTOMS	POSSIBLE CAUSES	CORRECTIVE ACTION
Red LED flashing quickly after an assisted setup.	The sensor 'sees' the door movement and can not finish its setup.	Adjust the position of the IR curtains.
Orange LED permanently ON after an assisted setup.	The sensor encounters a signal saturation.	Use the wide-field prism and/or slightly increase the IR curtains angle (turning the screw counterclockwise).
Red LED permanently ON after an assisted setup.	The sensor fails the IR test.	Cut and restore the power supply. Launch a new assisted setup. If the LED still stays ON, replace the sensor.
Orange LED ON	The sensor encounters a signal saturation.	Use the wide-field prism and/or slightly increase the IR curtains angle (turning the screw counterclockwise). Launch an assisted setup.
Orange LED flashes	The sensor signals an internal fault.	Cut and restore the power supply. If the orange LED lights up again, replace faulty sensor.
Red LED ON	The sensor detects a presence.	Wait the time set in 'maximum duration of presence detection' setting or launch an assisted setup (with the remote control or right push button).
Unwanted presence detection	The sensor is not placed properly and/or the front face is not properly fixed.	Fasten the sensor firmly and/or check whether the front face prism is placed into the foreseen slides and not in the sensor cover.
Door keeps recycling open-closed.	The sensor is disturbed by the door motion because it sees the door or because of vibrations.	Increase the IR curtains angle (turning the screw counterclockwise).
The door is not closing. LED OFF	On-Off switch at door control is in wrong position or is faulty. Improper output configuration on the sensor. Improper door control configuration	Check to insure that On-Off switch for door is in the ON or AUTOMATIC position. Check the output configuration setting on each sensor. Verify that 'Door Control' (F2) is set to 'Normal'
The presence detection is disturbed by the rain (red LED)	Heavy Rain	Increase the immunity of the curtains (immunity 2 or 3) Install a universal rain cover (PN: 10URC)
The sensor does not respond to the remote control.	1. Batteries in the remote control are dead or not installed properly. 2. Remote control badly pointed.	1. Check to insure that the batteries are installed correctly or replace batteries. 2. Point the remote control directly towards the sensor and move closer if necessary.
The sensor does not unlock when access code is entered.	Improper code being entered.	Cut and restore power supply. No code is required to unlock during the first minute after powering. Press UNLOCK, then LOCK and introduce a new access code (See Page 5).

10 Company Contact



Do not leave problems unresolved. If a satisfactory solution cannot be achieved after troubleshooting a problem, please call BEA, Inc. If you must wait for the following workday to call BEA, leave the door inoperable until satisfactory repairs can be made. Never sacrifice the safe operation of the automatic door or gate for an incomplete solution.

The following numbers can be called 24 hours a day, 7 days a week. For more information, visit www.beasensors.com.

US and Canada: 1 866.249.7937
Canada: 1 866.836.1863
Northeast: 1 866.836.1863

Southeast: 1 800.407.4545
Midwest: 1 888.308.8843
West: 1 888.419.2564